



## Universal Oven UF750

Precise drying, heating, ageing, burn-in and hardening in research, science, industry and quality assurance.



The universally applicable lab oven U is Memmert's classic appliance for temperature control in science, research and material tests in industry. The technologically perfected masterpiece made of high-quality, hygienic, easy-to-clean stainless steel leaves nothing to be desired in terms of ventilation and control technology, overtemperature protection and precisely tuned heating technology.

On this page, you can find all the essential technical data on the universal Memmert lab oven. Our customer relations team will be pleased to help if you want further information. If you should require a customised special solution, please contact our technical specialists at [myAtmoSAFE@memmert.com](mailto:myAtmoSAFE@memmert.com).

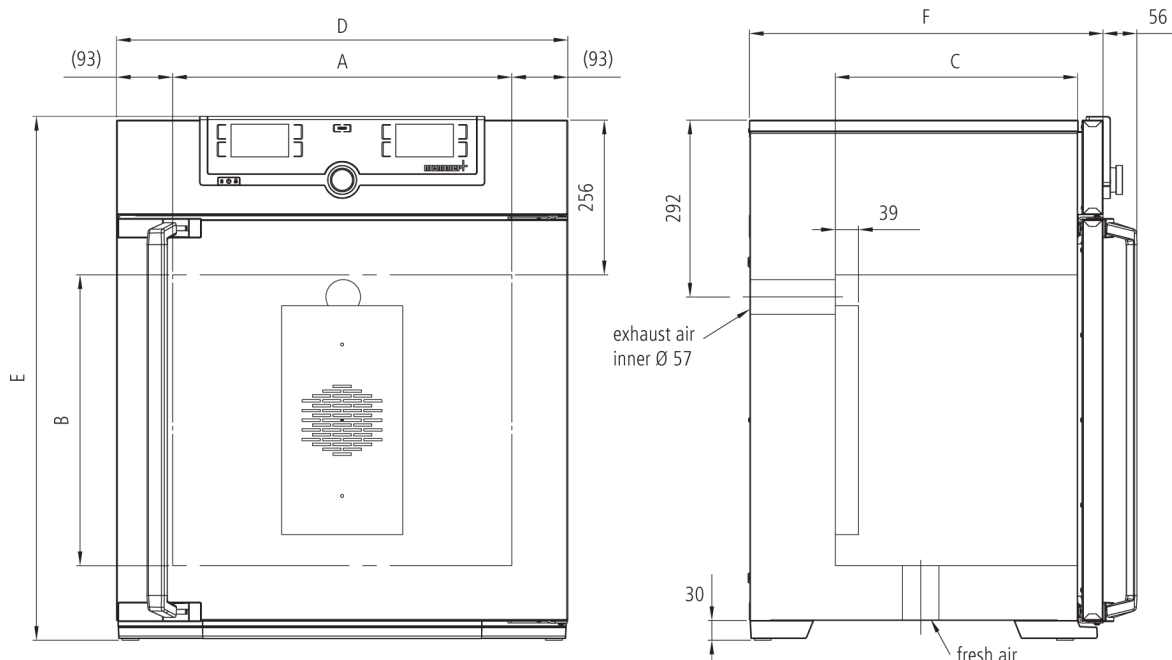

## Control of standard components

<b>ControlCOCKPIT</b>	adaptive multifunctional digital PID-microprocessor controller with high-definition TFT-colour display
<b>Temperature</b>	1 Pt100 sensor DIN class A in 4-wire-circuit
<b>Timer</b>	Digital backwards counter with target time setting, adjustable from 1 minute to 99 days

## Temperature

<b>Set temperature range in °C</b>	min.10°C above ambient up to +300°C
	resolution of display for setpoint values 0.1°C up to 99.9°C, 0.5°C from 100°C and for actual values 0.1°C (LED)

## Control technology

<b>adjustable parameters</b>	temperature (Celsius or Fahrenheit), fan speed, air flap position, programme time, time zones, summertime/wintertime
<b>Function SetpointWAIT</b>	the process time does not start until the set temperature is reached
<b>Language setting</b>	German/English/Spanish/French
<b>Calibration</b>	three freely selectable temperature values

## Ventilation

<b>Fan</b>	forced air circulation by 2 quiet air turbines, adjustable in 10 % steps
<b>Fresh air admixture</b>	adjustment of pre-heated fresh air admixture by air flap control in 10 % steps
<b>Vent</b>	vent connection with restrictor flap

## Communication

<b>Programming</b>	AtmoCONTROL software for reading out, managing and organising the data logger via Ethernet interface (temporary trial version can be downloaded). USB stick with AtmoCONTROL software available as accessory (on demand).
<b>Documentation</b>	programme stored in case of power failure

## Safety

<b>Temperature control</b>	adjustable electronic overtemperature monitor and mechanical temperature limiter TB, protection class 1 according to DIN 12880 to switch off the heating approx. 20°C above nominal temperature
<b>Autodiagnostic system</b>	for fault analysis

## Standard equipment

<b>Door</b>	fully insulated stainless steel doors with 2-point locking (compression door lock)
<b>Installation</b>	on lockable castors
<b>Internals</b>	2 stainless steel grids
<b>Scope of delivery</b>	incl. works calibration certificate for +160°C
<b>Housing</b>	rear zinc-plated steel
<b>Interior</b>	easy-to-clean interior, made of stainless steel, reinforced by deep drawn ribbing with integrated and protected large-area heating on four sides

### Stainless steel interior

$w_{(A)} \times h_{(B)} \times d_{(C)}$ : 1040 x 1200 x 600 mm

---

Volume 749 l

---

Max. loading of chamber: 300 kg

---

### Textured stainless steel casing

$w_{(D)} \times h_{(E)} \times d_{(F)}$ : 1224 x 1726 x 784 mm

---

### Electrical data

400 V, 3 phases, 50 Hz / approx. 7000 W

---

### Packing/shipping data

**the appliances must be transported upright**

---

**Customs tariff number** 8419 8998

---

**Country of origin** Federal Republic of Germany

---

**WEEE-Reg.-No.** DE 66812464

---

Dimensions approx incl. carton B x H x T: 1330 x 1910 x 1050 mm

---

Net weight approx. 217 kg

---

Gross weight carton approx. 288 kg

---