



Incubator IF110

The incubator I is at home everywhere in the world of research, medicine, pharmaceuticals and food analytics, as well as food chemistry.



With the help of our model selection, with dimensioned model sketches and extensive technical data for download, you can find the right incubator for your needs. The flexibility and technical features of our appliances meet all possible needs. Put us to the test!

From 32 models, expandable with convenient, approved and tested accessories, you will easily find the incubator ideally suited to your needs. According to your individual application the two model variants SingleDISPLAY cover all requirements of thermal safety, precision and quality assurance.

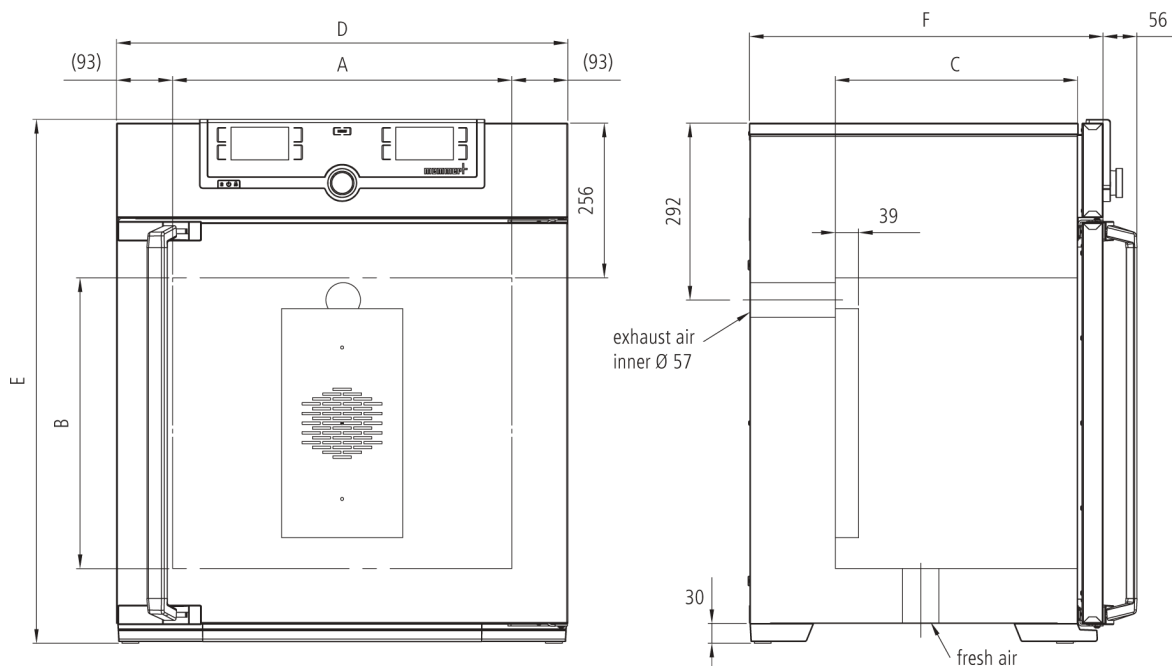

Control of standard components

Control	COCKPIT adaptive multifunctional digital PID-microprocessor controller with high-definition TFT-colour display
Temperature	1 Pt100 sensor DIN class A in 4-wire-circuit
Timer	Digital backwards counter with target time setting, adjustable from 1 minute to 99 days

Temperature

min. 10°C above ambient up to +80°C

resolution of display for setpoint and actual temperature values

Control technology

adjustable parameters	temperature (Celsius or Fahrenheit), fan speed, air flap position, programme time, time zones, summertime/wintertime
Function Setpoint	WAIT the process time does not start until the set temperature is reached
Language setting	German/English/Spanish/French
Calibration	three freely selectable temperature values

Ventilation

Fan	forced air circulation by quiet air turbine, adjustable in 10 % steps
Fresh air admixture	adjustment of pre-heated fresh air admixture by air flap control in 10 % steps
Vent	vent connection with restrictor flap

Communication

Programming	AtmoCONTROL software for reading out, managing and organising the data logger via Ethernet interface (temporary trial version can be downloaded). USB stick with AtmoCONTROL software available as accessory (on demand).
Documentation	programme stored in case of power failure

Safety

Temperature control	adjustable electronic overtemperature monitor and mechanical temperature limiter TB, protection class 1 according to DIN 12880 to switch off the heating approx. 20°C above nominal temperature
Autodiagnostic system	for fault analysis

Standard equipment

Door	fully insulated stainless steel door with 2-point locking (compression door lock)
Door	inner glass door
Internals	2 stainless steel grids
Scope of delivery	incl. works calibration certificate for +37°C
Housing	rear zinc-plated steel
Interior	easy-to-clean interior, made of stainless steel, reinforced by deep drawn ribbing with integrated and protected large-area heating on four sides

Stainless steel interior

$w_{(A)} \times h_{(B)} \times d_{(C)}$: 560 x 480 x 400 mm

Volume 108 l

Max. loading of chamber: 175 kg

Textured stainless steel casing

$w_{(D)} \times h_{(E)} \times d_{(F)}$: 745 x 864 x 584 mm

Electrical data

230 V, 50/60 Hz / approx. 1400 W

115 V, 50/60 Hz / approx. 1100 W

Packing/shipping data

the appliances must be transported upright

Customs tariff number 8419 8998

Country of origin Federal Republic of Germany

WEEE-Reg.-No. DE 66812464

Dimensions approx incl. carton B x H x T: 830 x 1050 x 800 mm

Net weight approx. 78 kg

Gross weight carton approx. 103 kg
